



Process Engineered Water Equipment



Amerities South- railroad tie facility:

New process equipment for clarification of aerobically treated industrial waste-streams.

By Stuart Ward
General Manager
ward@pewe-usa.com



T²-Max™ Thickener DAF

Summary

PEWE has developed a new patent pending process equipment system for clarifying mixed solids flows of aerobically treated waste streams. It is a dissolved air flotation clarifier, or commercially the PEWE **T²-Max™ Thickener DAF**. The object of clarification is to eliminate the major portion of the impurities and/or solid materials in suspension within the waste-stream. The system utilizes several innovative patent pending process enhancement technologies. In its simplest terms, the machine injects very fine micro-bubbles into a chemically treated water flow post aerobic process in order to create separation between the water and any suspended impurities such as biomass. The first such system, a PEWE model **TM-25** is at the newly constructed Amerities South facility in Hope AR, USA.

Client Application

The **T²-Max™ Thickener DAF** has been specified for the Amerities South rail road tie production facility. The new DAF and attendant ancillary PEWE equipment sub-systems are arranged such that gravity provides for the waste-stream's process flow. This helps reduce the systems carbon footprint by reducing energy consumption.

The process goal of this project is the efficient removal of biomass and other constituents (both suspended and dissolved) from a rail road tie plant wastewater stream. The wastewater consists primarily of TSS, BOD and FOG and other polynuclear aromatic hydrocarbon (PAH) compounds from the plant manufacturing and storm water capture areas.

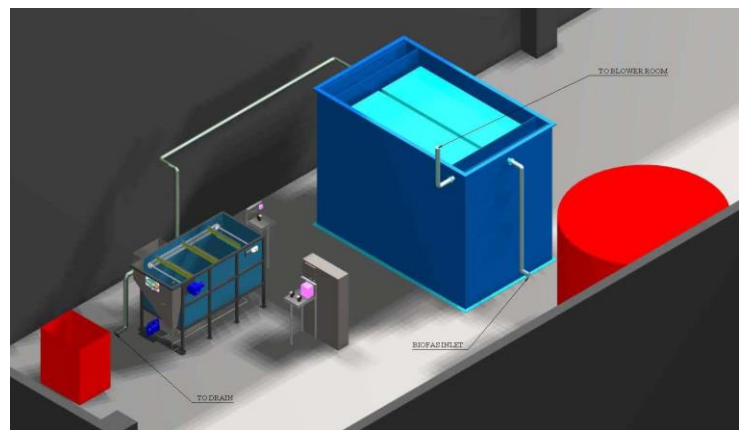

Amerities South Wastewater Treatment Facility

Water Quality Parameters

<u>Water Quality Parameters</u>		<u>Limits</u>
Average Flow	5,000 gpd	none
Maximum Flow	15,000 gpd	none
TSS	~450 ppm	200 ppm
BOD	~360 ppm	200 ppm
FOG	~100 ppm	50 ppm
pH	6.0 to 9.0	6.0 to 9.0
Temp	110°F	None

The complete system package downstream of the aerobic biological treatment unit includes the **T²-Max™ Thickener DAF** and two **PolyAccu Dose™** units for both flocculent and nutrient feeds. PEWE rounded out the system with a centrally located and free standing integrated **Command Control™** PLC.

Equipment Description



ParaLam Weir™

The PEWE *T²-Max™ Thickener DAF* system comprises several operations. The system aerates the waste stream before subjecting it to filtration separation in order to obtain a retentate and a clarified filtrate. The system then concentrates and dewateres the retentate. Both the retentate (bio-solids) and clarified filtrate (effluent water) then pass separately downstream prior to discharge to the POTW as well as solids reuse or disposal.

The liquid/solids separation process starts with the biologically treated waste-stream passing into an integral pipe flocculator where chemistry is applied. This provides a continuous flow reaction to enhance the coagulation and flocculation of the suspended particles. As the particles agglomerate they are subjected to aeration with very fine 20-30 micron micro-bubbles from a Rogue Pump Company *MAX RGT™* regenerative turbine pump. The bubbles mix and attach themselves to the particles changing their density relative to the water.

The aerated floc and water next enters the *T²-Max™ Thickener DAF* vessel where the multi-stage filtration operation occurs. The water starts first in the *Stilling Well Vortex™* chamber where dense solids are immediately dropped out. The system then passes the flow into the main chamber while evenly distributing the water and maintaining laminar conditions. Here solid particles rise to the surface of the vessel where they are concentrated for collection as a floating skim-able mass and are mechanically swept up a dewatering surface before falling into the solids hopper. From here the solids are transferred for further plant reprocessing or disposal, while the clarified water is removed from the vessel with patent pending adjustable self-cleaning *ParaLam Weirs™*.

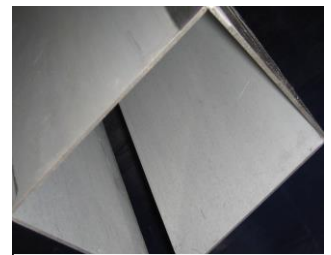

ParaLam Weir™ Cut-Away

System Specifications

Capacity	25gpm
Length	108"
Width	60"
Height	72"
Dry Weight	1750lbs
Wet Weight	8050lbs
Sep. Area	30ft ²
Air : Solids	0.028 (4X min)

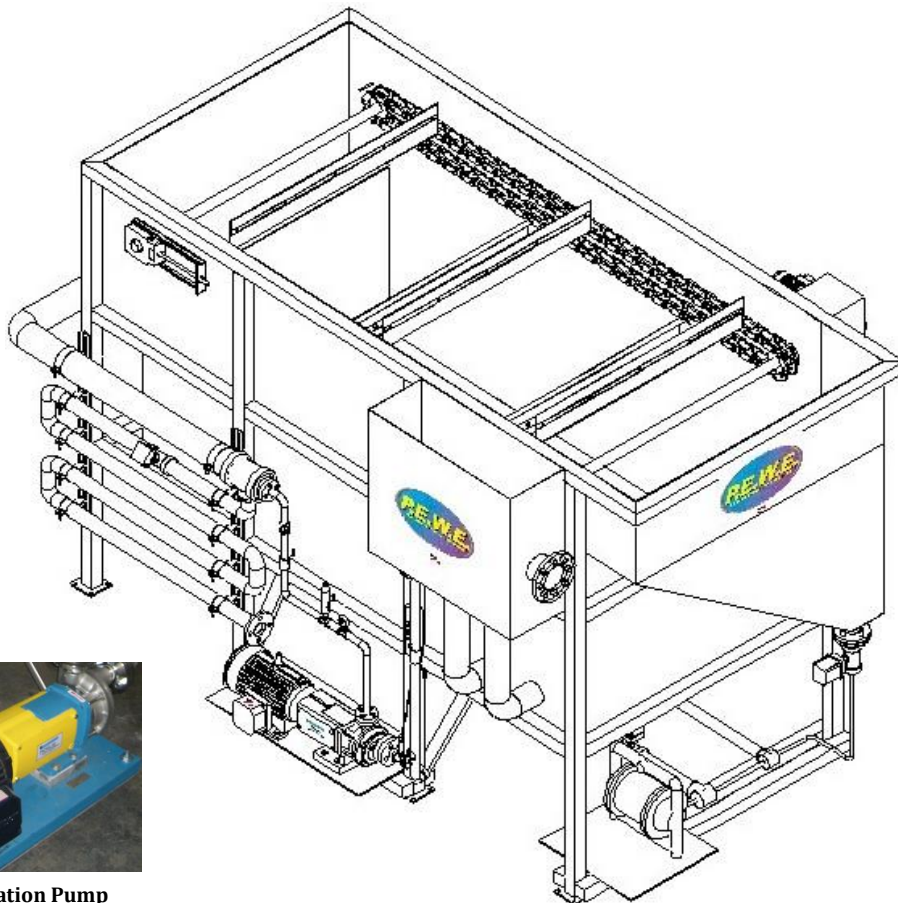

*MAX RGT™ Aeration Pump
Model: 10FS*



*PolyAccu Dose™
Model: PAD-10F*



*T²-Max™ Thickener DAF
Model: TM-25*

