



## SuperScreen® SSI

### Internally-Fed Screen

#### PEWE SuperScreen® SSI

Internally fed screen units are used for the removal of large insoluble material from an aqueous solution. Screens are used on process and wastewater streams for particles that need to be removed in order to protect downstream systems. The screen can also be used for product recovery, fat removal, high solids loading, sludge thickening and mixed settle-able solids for both municipal and industrial applications.

The **SuperScreen® SSI** series maximize solids removal in an easy to maintain unit. The screen is a barrier by which material larger than the gap or slot size may not pass, allowing the water to continue through.



SuperScreen® SSI-72.3  
without enclosure

#### SuperScreen® SSI Design

The internal design utilizes a cylindrical wedgewire drum. The screen may be ordered with several options including perforated drum, enclosure cover, auto spray mechanism and **Command Control®** panel.

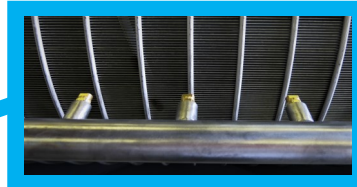

#### Auto Spray & Quality Components

#### SuperScreen® SSI Operation

The internally fed screen operates by feeding the solids laden influent water to the headbox. The water is then distributed evenly onto the interior sidewalls of the rotating drum. Solids collect onto the interior drum surface as the water passed through the screen into a catch pan. Flights convey the solids forward, further dewatering them as they "roll up" and out the end of the barrel.

#### Internally Fed Screens - High Flows, High Solids

- Bakery
- Brewery
- Fruit
- Food Process
- Meat
- Mineral
- Municipal
- Petro-Chemical
- Poultry
- Pulp & Paper
- Seafood
- Vegetable
- Winery
- Waste Water

Application	Wedgewire	Model		Flow	Capacity	English or Metric		GPM
Type	Slot	SSI-18.2	SSI-36.2	SSI-72.3	SSI-96.4	SSI-120.4	SSI-120.5	SSI-160.6
Fruit & Veg	.030"	80	200	800	1350	1700	3000	4500
Seafood	.020"	60	160	590	950	1400	2300	3000
Meat	.030"	60	175	625	1050	1500	2400	3150
Municipal	.040"	90	400	1800	2800	4150	6750	8500
Poultry	.020"	60	160	590	1000	1400	2400	3150
Pulp & Paper	.030"	90	175	600	1100	1650	2200	2900
Petroleum	.010"	60	105	490	950	1250	2000	2750

This chart to be used as a guide only. Consult your PEWE representative.





# LIQUID/SOLID SEPARATION SYSTEMS

SCREENING, GRAVITY, FLOTATION, DEWATERING & ACCESSORIES

## Questions?

Please inquire about our **SuperScreen® SSI** Internally-Fed Systems, or any of our other wastewater screening equipment, feel free to contact us at your earliest convenience. We are happy to answer any questions you have about our products and to help you find the perfect wastewater screening equipment for your needs. Our selection is second to none in the industry.

**SuperScreen® SSI-72.3**  
with enclosure

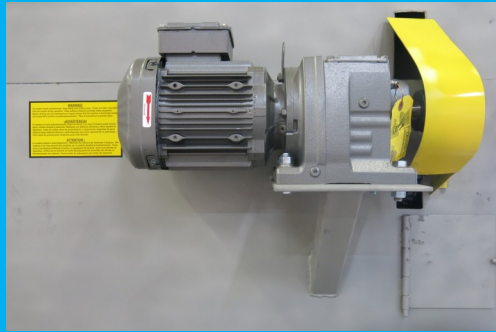

### 1 - Drive Assembly

The screen drum shall be driven by a chain and gear system. The gear box will feature helical gear reducer. The motor will be a select hp, @ 1,750 rpm, 460v, 3 Ø, 60 Hz TEFC motor with class F insulation and a 40 degree C temperature rating, suitable for VFD control.

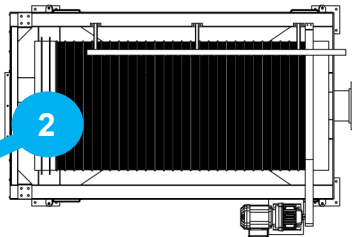

### 2 - Screen Assembly - Wedgewire Drum

The screen drum will be constructed of 304 stainless steel. The screen element will be of wedgewire design with the profile wires resistance welded to the cylinder support rods.

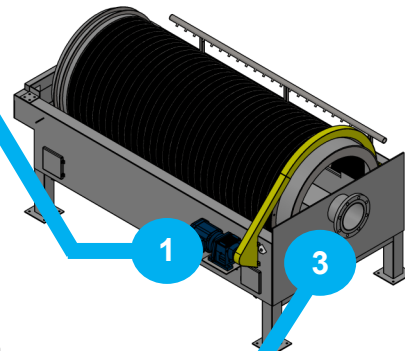

### 3 - Influent Head Box

The head box is mounted on the inlet end of the housing and extends into the interior of the drum. Internal baffles and splash plates distribute the water evenly onto both sides of the drum screen.

